

PREMIERTRAK 300/R300

The Powerscreen® Premiertrak 300 range of high performance primary jaw crushing plants are designed for medium scale operators in quarrying, demolition, recycling & mining applications. The range includes the Premiertrak 300 with hydraulic adjust & the Premiertrak R300 with hydraulic release. User benefits include track mobility for a quick set-up time, hydraulic crusher setting adjustment for total control of product size and crusher overload protection to prevent damage by un-crushable objects.

An optional hydrostatic drive system offers versatility and allows the crusher to be operated in reverse, of particular benefit in recycling applications.

Features & Benefits

- Ground level quick set-up with hydraulic folding feed hopper with hydraulic locking pins
- Heavy duty wear resistant feed hopper
- Stepped grizzly feeder with under-screen
- Wide bypass chute to optimise material flow
- Aggressive crushing action with high swing jaw encouraging material entry into crushing chamber
- Fully hydraulic crusher setting adjustment
- Improved manganese liner retention, protects jaw supports on both swing & fixed jaws
- Excellent under crusher access for removal of wire with hydraulic raise lower product conveyor
- Angle adjustable product conveyor, lowers for access & transport
- Low fuel consumption due to highly efficient direct drive system and low engine RPM
- Easily accessed powerunit canopy
- PLC control system with auto start facility
- Remote control via umbilical
- Dust suppression system

Options

- Deflector plate under crusher
- Dirt conveyor
- Single pole/twin pole magnet
- Radio remote control
- Belt weigher
- Electric refuelling pump
- Hydraulic water pump
- Urea refuelling pump
- Pre-screen system
- Stockpiler drive

Applications

- Blasted rock
- River rock
- C & D waste
- Foundry waste
- Processed ores
- Processed minerals

Output Potential

Up to 280tph (308 US tph)*

Product Conveyor

Width: 900mm (36")
Discharge height: 3.4m (11' 2")

Crusher

High capacity single toggle jaw
Chamber size: 1000mm x 600mm (40" x 24")
Min CSS: 40mm (1.5")*
Max CSS: 145mm (5")*

Hopper

Abrasion resistant feed hopper
Length: 4.3m (14' 1")
Width: 2.05m (6' 8")
Capacity: 5m³ (6.5yds³)

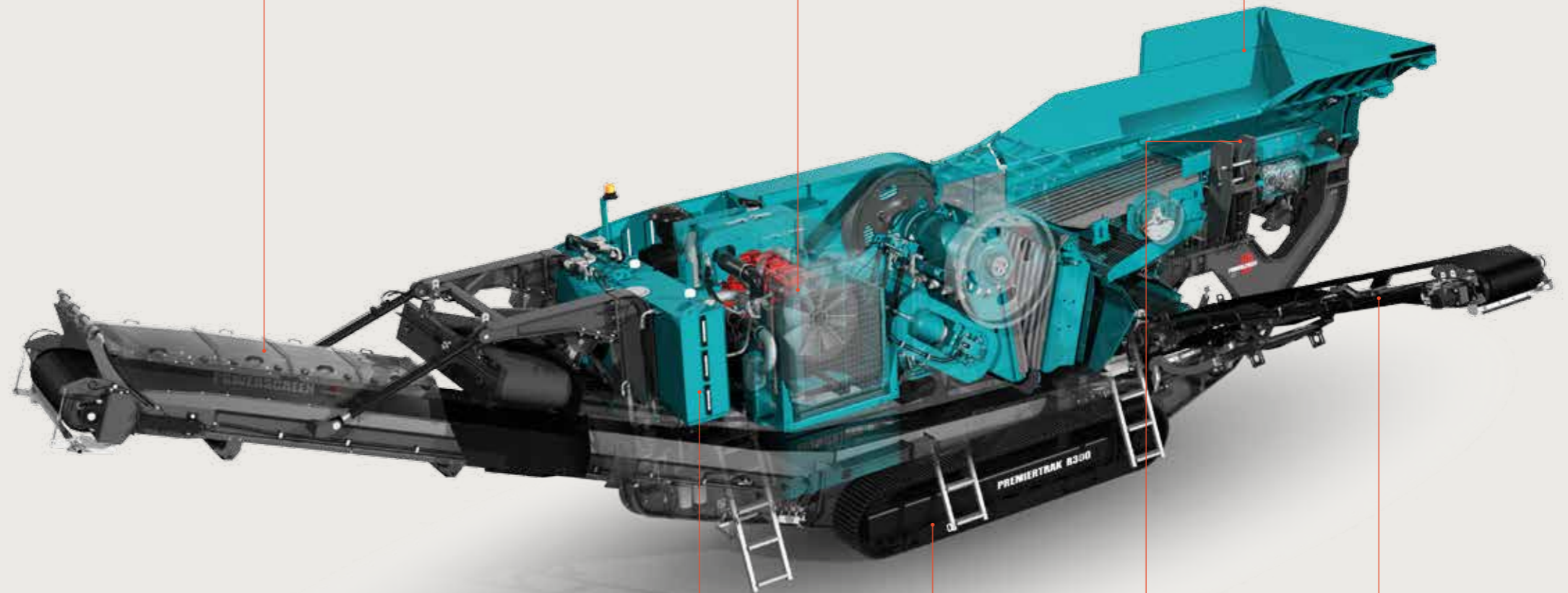

PREMIERTRAK 300/R300	300	R300
Weight (est.)	33,000kg (72,752lbs)	34,650kg (76,390lbs)
(with side conveyor & magnet)	35,000kg (77,162lbs)	36,650kg (80,799lbs)
Transport width	2.55m (8'5")	2.55m (8'5")
Transport length	14.6m (47'11")	14.6m (47'11")
Transport height	3.2m (10'6")	3.2m (10'6")
Working width	2.55m (8'5")	2.55m (8'5")
(with side conveyor)	6.28m (20'7")	6.28m (20'7")
Working length	14.7 (48'3")	14.7 (48'3")
Working height	3.85m (12'8")	3.85m (12'8")



*Depends on application
Engines are available that are certified to US EPA and EU off road diesel emission standards. Talk to your dealer about possible certification options (i.e. Tier 3/Stage 3A, Tier 4/Stage 3B, Tier 4F / Stage 4).

Power Unit

Tier 3/Stage 3A:
CAT C9 205kW (275hp)
Tier 4/Stage 3B:
Scania DC9 202kW (275hp)
Fuel tank capacity: 520 L (137 US Gal)

Tracks

Width: 400 mm (15.7")

Feeder

Vibrating pan and grizzly feeder
Pan length: 1.73m (5' 8")
Pan width: 0.9m (3')
Grizzly length: 1.9m (6' 3")
Grizzly width: 0.9m (3')

Side Conveyor (option)

Width: 650mm (2' 2")
Discharge height: 2.8m (9'2")
Discharge height: 3.1m (10'2")
(extended conveyor option)

