

Powerscreen® Powertrak 750 Scalping Screen

SPECIFICATION - Rev 3. 01/01/2017



POWERSCREEN
CELEBRATING 50 YEARS
OF POWER 2016

50



Powerscreen® Powertrak 750

SPECIFICATION Rev 3. 01/01/2017

Specification		Powertrak 750
Total weight		19,000kg (41,890lbs)
Transport	Length	9.43m (31')
	Width	2.82m (9' 3")
	Height	3.2m (10' 6")
Working	Length	10.5m (34' 7")
	Width	2.65m (8' 8")
	Height	4.27m (14' 4")
Screen Unit:		4.5m x 2.75m (14'8" x 9')
Powerunit:		Diesel Hydraulic
Paint colour:		Blue RAL 5021, Grey RAL 7024, Black RAL 9005

Features & Benefits

The Powerscreen® Powertrak 750 is a self-contained high capacity mobile scalping unit. With its robust construction the Powertrak 750 can easily withstand the toughest scalping applications and is versatile enough to perform at an equally high level in fine screening applications.

The vibrating grid length offers a huge target area which ensures straightforward feeding with either a wheel loader or an excavator. This coupled with its compact, sleek design and ease of movement makes the Powertrak 750 the ultimate choice for contractors, quarry operators & recycling customers.

- Output potential up to 600tph (660 US tph) (Depending on application & media fitted)
- Quick set-up and tear down times
- Easily transported
- Maximum mobility with heavy duty, low ground pressure crawler tracks
- High performance hydraulic system - cast iron pumps & motors complete with hydraulic cooler
- Efficient design with low fuel consumption
- User-friendly operation & maintenance
- Class-leading stockpiling capacity
- Easily accessed powerunit canopy

Applications

Aggregate

- Sand & gravel
- Blasted rock
- River rock

Recycling

- C&D waste
- Overburden
- Foundry waste
- Topsoil

Mining

- Processed ores
- Processed minerals

POWERSCREEN
CELEBRATING 50 YEARS
OF POWER 2016



All specifications subject to change without prior notice



Powerscreen® Powertrak 750

SPECIFICATION Rev 3- 01/01/2017

Vibrating Grid & Hopper

Split level scalping grizzly with 3 T-Bar interchangeable cassettes and feed plate, mounted on 12 heavy duty springs.
3 easy-to-change end-tensioned meshes on bottom deck
Standard grid opening 150mm (6"), Optional 100mm (4")
Standard bottom deck woven mesh aperture (60mm) (2.4")

Grid opening: 3.35m (11')
Feed opening with wing plates: 4.41m (14' 6")
Grid length: 2.6m (8' 7") (with feed plate)
Grid aperture: 100mm (4"), 150mm (6")
Grid angle: hydraulically variable between 2° and 25°
Hopper capacity: 5m³ (6.5 yd³)

Heavy duty feed shroud supported from grid sub-frame



Discharge Conveyor

1.2m (48"), EP 500 / 3ply belt with 5+1,5mm cover
Hydraulic drive with steel skirting
Heavy duty impact roller in hopper

Dual speed belt: 46 & 75 metres per minute
Twin drive system

Discharge height: 3.4m (11' 2")
Stockpile capacity: 83m³ (108.6yd³)

Hydraulic folding for transport



Crawler Track Data

Shoe width: 400mm (16")
Sprocket centres: 2.92m
Gradability degrees: 30°
Tracks fully protected by heavy duty deflector plate
Optional radio remote control



Power unit & Hydraulics

EU Stage IIIA / US Tier 3 Engine: Deutz D914 L04 air cooled
EU Stage IIIA / US Tier 3 Engine: Power: 53kW (74hp)
EU Stage IIIA / US Tier 3 Engine: Speed: 2300 rpm

EU Stage IV / US Tier 4F Engine: Caterpillar C3.4
EU Stage IV / US Tier 4F Engine: Power: 56kW (75hp)
EU Stage IV / US Tier 4F Engine: Speed: 1800 rpm

Hydraulic tank: 536 litres (142 US Gallon)
Diesel tank: 145 litres (142 US Gallon)

Standard hydraulic oil — Century 46
Optional hydraulic oil — Century 100

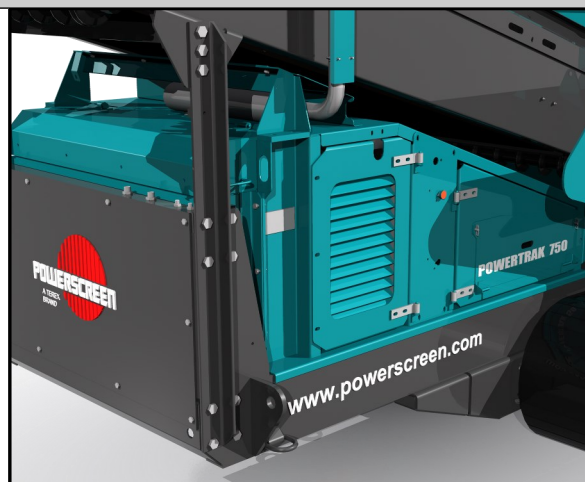

POWERSCREEN
CELEBRATING 50 YEARS
OF POWER 2016



All specifications subject to change without prior notice



Powerscreen® Powertrak 750

SPECIFICATION Rev 3. 01/01/2017

Powerscreen Pulse

Powerscreen Pulse is a system which allows the machine to relay data via phone networks, or by satellite when there's no cellular signal, to any device with a web browser, such as a PC, tablet or Smartphone.

Please contact the factory for further information.



POWERSCREEN
CELEBRATING 50 YEARS
OF POWER 2016



All specifications subject to change without prior notice



Powerscreen® Powertrak 750

SPECIFICATION Rev 3. 01/01/2017

Powertrak 750 Working Dimensions

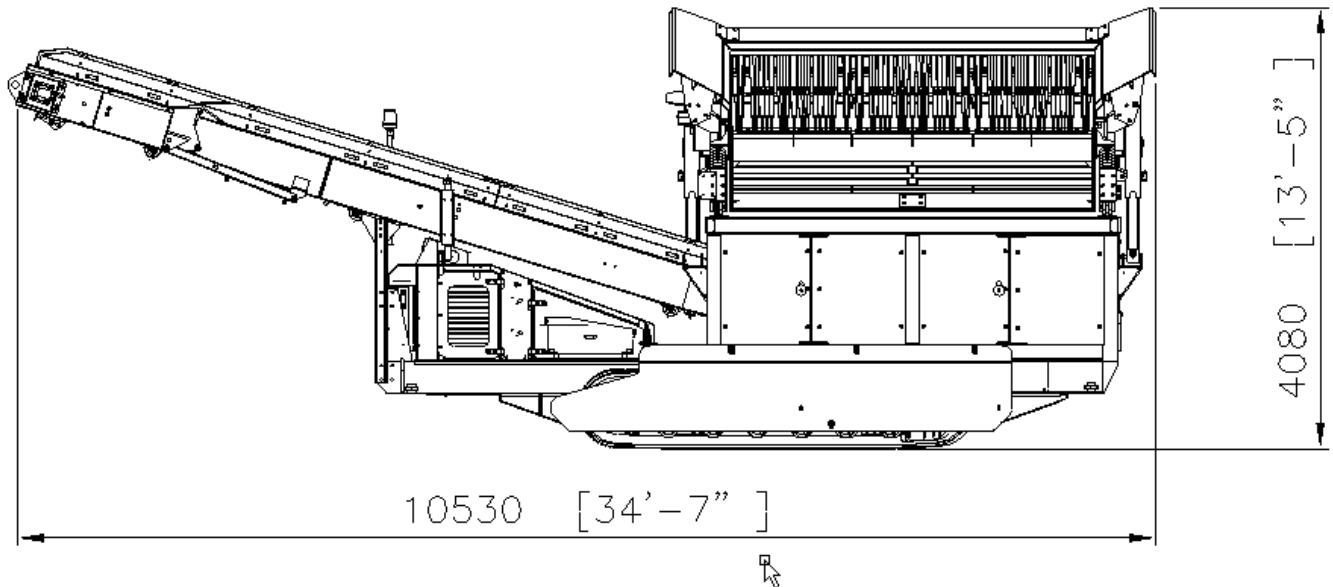

2648 [8'-8"]

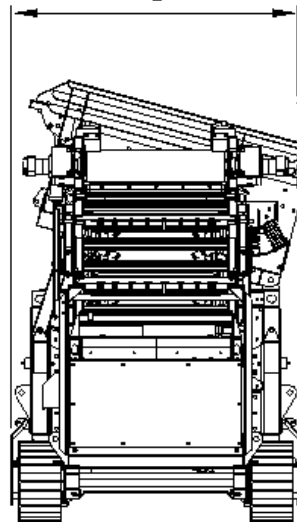

NOTE: GRID SET AT 15 DEGREES

POWERSCREEN
CELEBRATING 50 YEARS
OF POWER 2016

50

All specifications subject to change without prior notice



Powerscreen® Powertrak 750

SPECIFICATION Rev 3. 01/01/2017

Powertrak 750 Transport Dimensions

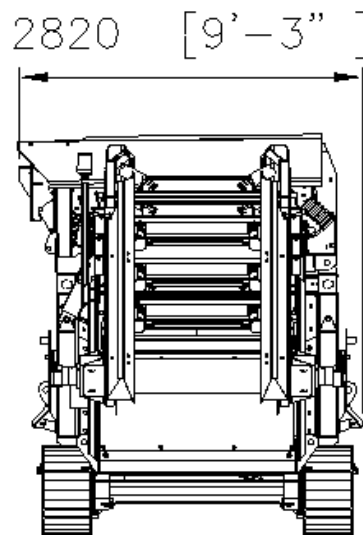
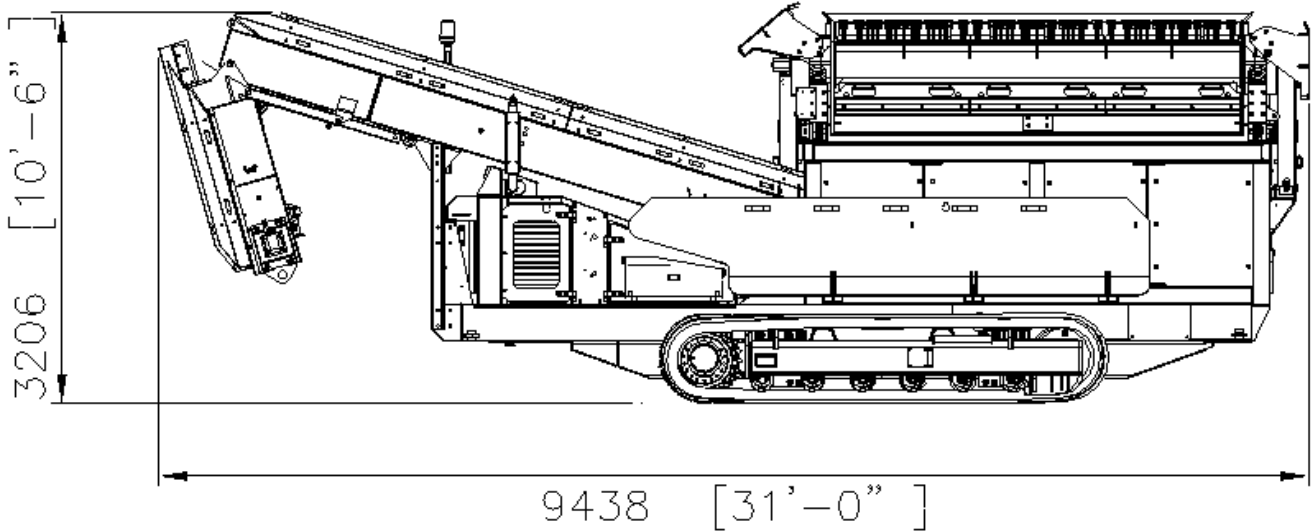

POWERSCREEN
CELEBRATING 50 YEARS
OF POWER 2016

50

All specifications subject to change without prior notice



Powerscreen® Powertrak 750

SPECIFICATION Rev 3. 01/01/2017

Powerscreen equipment complies with CE requirements.

Please consult Powerscreen if you have any other specific requirements in respect of guarding, noise or vibration levels, dust emissions, or any other factors relevant to health and safety measures or environmental protection needs. On receipt of specific requests, we will endeavour to ascertain the need for additional equipment and, if appropriate, quote extra to contract prices.

All reasonable steps have been taken to ensure the accuracy of this publication, however due to a policy of continual product development we reserve the right to change specifications without notice.

It is the importers' responsibility to check that all equipment supplied complies with local legislation regulatory requirements.

Plant performance figures given in this brochure are for illustration purposes only and will vary depending upon various factors, including feed material gradings and characteristics. Information relating to capacity or performance contained within this publication is not intended to be, nor will be, legally binding.

Terex GB Ltd.
200 Coalisland Road
Dungannon
Co. Tyrone
Northern Ireland
BT71 4DR

Tel: +44(0) 28 8774 0701
Fax: +44(0) 28 8774 6569

E-Mail: sales@powerscreen.com
Web: www.powerscreen.com

Terex is a registered trademark of Terex Corporation in the United States of America and many other countries.
Powerscreen is a registered trademark of Terex GB Ltd in the United States of America and many other countries.

Copyright Terex Corporation 2017

POWERSCREEN
CELEBRATING 50 YEARS
OF POWER 2016



All specifications subject to change without prior notice

