



A TEREX BRAND

PRODUCT SPECIFICATION

6400T

HORIZONTAL GRINDER/ CHIPPER



WHOLE TREES • STORM DEBRIS • SLASH • STUMPS • REGRIND

KEY FEATURES...

Four interchangeable rotors make this horizontal grinder one of the most versatile machines around. Weighing in between 83,000 and 90,000 pounds and designed to thrive in "less than wide-open conditions," this hog gets where you need it to go and produces an immaculate end product. The CBI Magnum Force 6400T provides the flexibility to process an exceptionally wide variety of materials and generate the end products your clients demand—all with a single machine. No other grinder is as productive, flexible, or compact as this tracked model.

Operators can transform this whole tree grinder into a machine built for grinding contaminated demolition debris just by swapping the rotor and screen(s). The rotor options available with this horizontal grinder are as rugged as they come. The solid steel rotor, with (20) 152 mm x 203 mm striker plates, is ideal for grinding contaminated railroad ties, municipal solid waste, and demolition debris. If you're in the market for forestry debris and mulch processing, the forged drum rotor with 101 mm hammers and reversible tips are your best option. Few machines have the ability to go into the woods and produce "port-quality" product; the 6400T gets it done.

The 6400T can also be converted to a whole tree chipper by installing a 2-pocket or 4-pocket chipper rotor. The 2-pocket rotor features two rows of knives for chip lengths of 19 mm to 32 mm for producing fuel chips from stemwood. The 4-pocket chipper rotor has four rows of knives for chip lengths of 2 mm to 12 mm. The four-pocket chipper rotor produces wood microchips from stemwood suitable as feed stock for producing wood pellets.

Customers can chip logs to various sized chips at rates up to 181 tons per hour thanks to its extensive power unit. It is powered by a CAT C27; 1050 HP engine. The 6400T is also equipped with a radiator featuring a Flexaire Auto-Reversible Fan for auto cleaning, a PT Tech hydraulic clutch with pump drive, and a CAT Air Filtering System.

Four interchangeable rotors. Next-generation versatility.

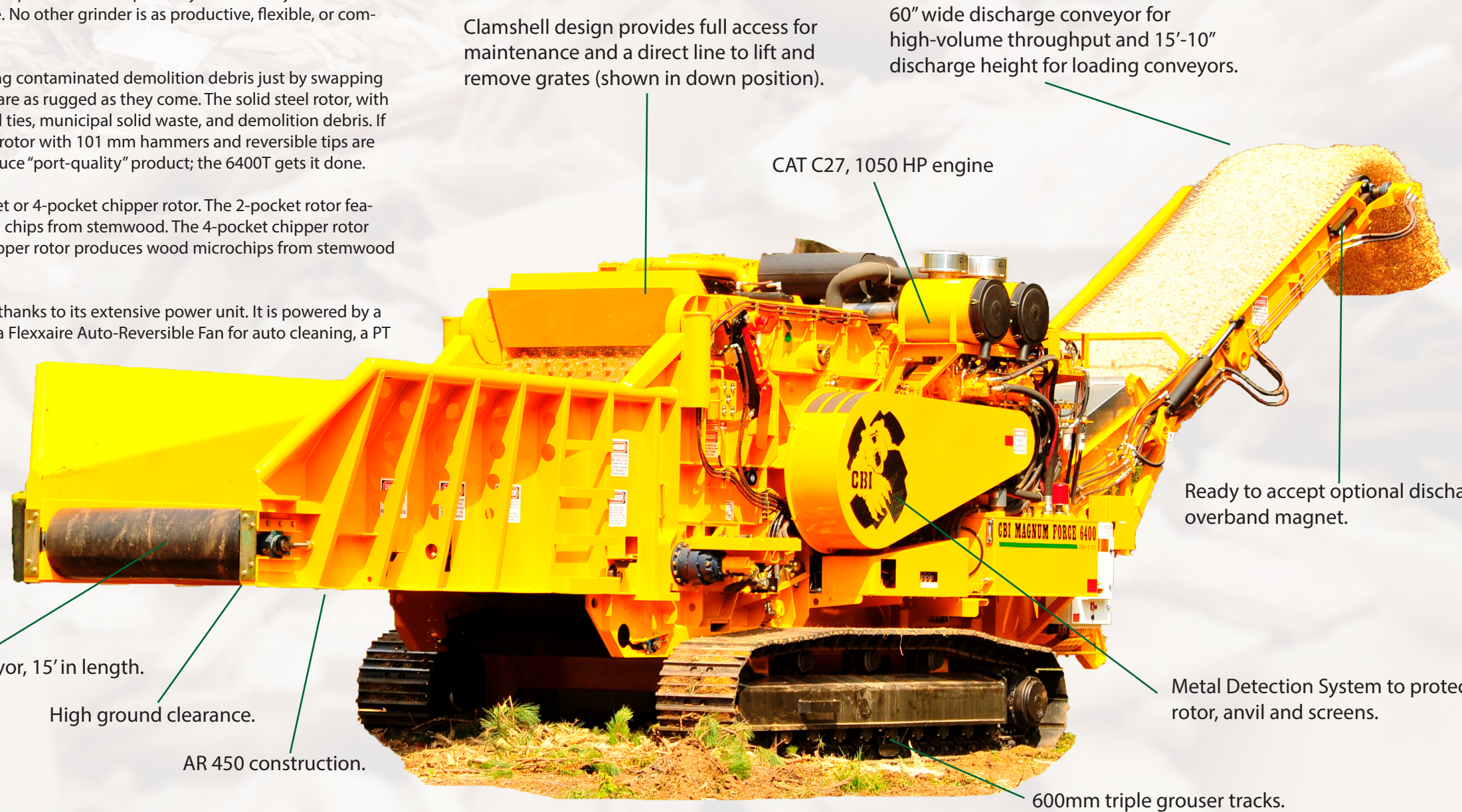

60" wide infeed conveyor, 15' in length.

High ground clearance.

AR 450 construction.

CAT C27, 1050 HP engine

60" wide discharge conveyor for high-volume throughput and 15'-10" discharge height for loading conveyors.

Ready to accept optional discharge overband magnet.

Metal Detection System to protect rotor, anvil and screens.

600mm triple grouser tracks.

Steel Drum

Twenty 6"x8" striker plates held in place by two 1-1/4" bolts, designed for contaminated demolition debris, railroad ties and MSW.

Forged Drum

3" thick rotor with twenty or twenty-four weld on Replace-A-Face™ hammers with reversible tips for forestry debris and mulch manufacturing.

2-Pocket Chipper

Two rows of knives for average chip lengths of 3/4" to 1-1/4" to produce fuel chips from stem wood.

4-Pocket Chipper

Four rows of knives for short chip lengths of 1/8" to 1/2" to produce short chips from stem wood suitable for pelletizing or pulverized fuel.

Unmatched versatility



"If my customers want the end product to be half-inch, one-inch, two inch – if they want it chipped or ground – we can do it. There's very few companies that offer a machine with the versatility to change from a grinder to a chipper and produce a ship-load of material."

Thomas Mckellar, owner of Site Prep

IQAN electric, hydraulic controls



Forged 40" x 60" downswing rotor

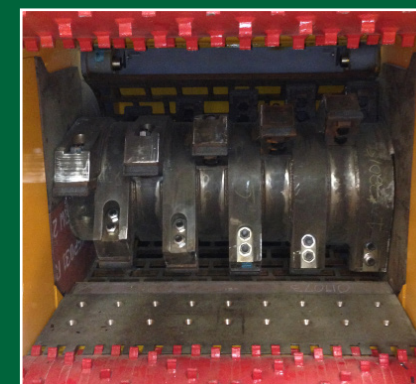

Various hammer inserts



METAL DETECTION SYSTEM



A problem for any industrial grinder has to do with tramp metal entering the hog box and causing significant damage, which leads to downtime. The Metal Detection System™ (MDS) engages within milliseconds whenever the grinder's rotor makes contact with tramp metal.

The rotor is monitored by an adjustable electronic sensor to alert the control system when tramp metal is detected. It will automatically stop the rotor, raise the top feed roller and reverse the infeed to allow the operator to find the tramp metal.

TRANSPORT DIMENSIONS

Width: 10'-2" (3 m)
 Height: 12'-0" (3.6 m)
 Length: 40'-10" (12.4 m)
 Weight: 83,000 - 90,000 lbs. (approx.)

DISCHARGE CONVEYOR

Width: 60" (1.5 m)
 Length: 37' (11.2 m)
 Height: 15'-10" (4.8 m)
 Discharge belt includes magnetic head pulley and chute

INFEED

Width: 60" (1.5 m)
 Height: 46" (1.1 m)
 Conveyor: 15'-0" (4.5 m), heavy-duty belting

ENGINE/DRIVE

Caterpillar C27; 1,050HP (787 kW)
 Fuel capacity 450 gallons (1,703 L)
 PT Tech HPTO15 clutch
 12 groove, 8-V section Arimid belt

FAN

Reversing pitch radiator fan that reverses airflow automatically

CONTROLS

Parker IQAN™
 Remote control operated

HYDRAULICS

Hydrostatic
 Hydraulic capacity 95 gallons (359 L)

EQUIPMENT PROTECTION

Metal Detection System™ (MDS)

TRACKS

D5 600 mm triple grouser

HAMMERMILL

Diameter: 40" (1 m)
 Width: 60" (1.5 m)
 Shaft: 6" (0.15 m)
 Top Feed Roll: 40" diameter x 60"

Specification subject to change without notice.

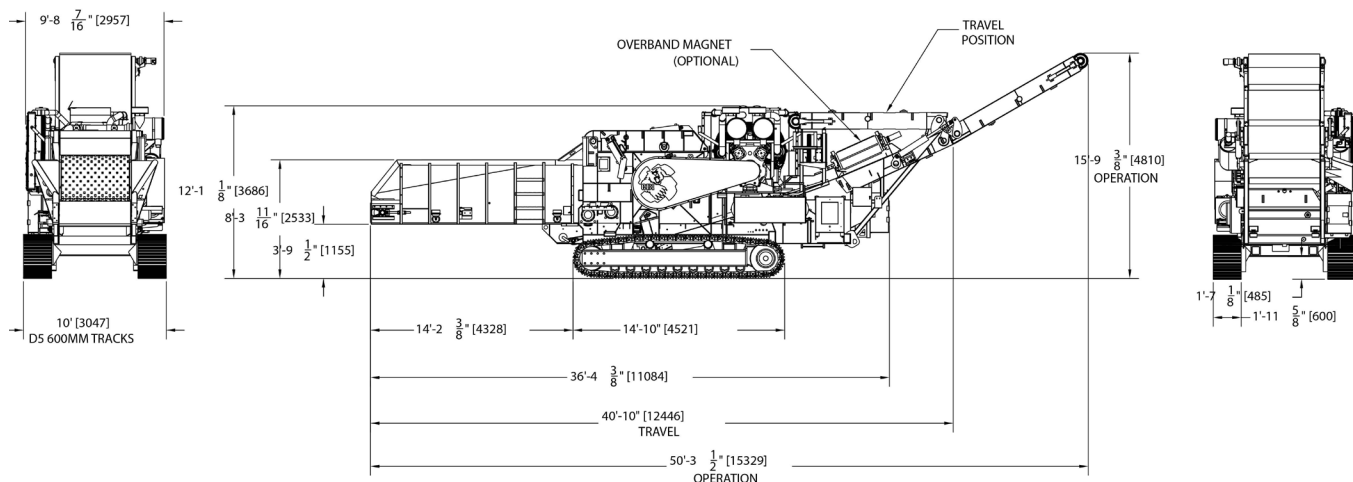

Continental Biomass Industries

World's best stationary and portable material recovery systems.

22 Whittier Street, Newton, NH, 03858
 Phone: (603) 382-0556 Fax: (603) 382-0557
 Web: cbi-inc.com Email: info@cbi-inc.com

Distributed by: